

PMAC FOUR AXIS BOX





PMAC Four Axes Box

Version 1.0

CONTENTS

Section	1.0	Four Axes Box
	1.0.1	Specification
	1.0.2	Description
	1.0.3	Ordering Information
Section	2.0	Recommended installation practices to conform with Council Directive 89/336/EEC
Section	3.0	Machine, Amplifier & Encoder Interface
	3.0.1	Specification
	3.0.2	Description
	3.0.3	Power connections
Section	4.0	Axis connections
	4.0.1	Axis flag input circuit
	4.0.2	Amplifier and encoder connections
Section	5.0	8 Input 8 Output opto-isolated Interface
	5.0.1	Input circuit detail
	5.0.2	Output circuit detail
Section	6.0	Other ports
	6.0.1	Serial port
	6.0.2	Thumbwheel multiplexer
	6.0.3	Handwheel port
Section	7.0	Four Axes Box software setup

1.0.1 Specification

Input Power Requirements.	24Vdc
Power Supplies.	I/O supply +24 VDC @ 1.5 amps. PMAC internal supplies +5 VDC @ 3 amps. +12 VDC @ 0.6 amps. -12 VDC @ 0.6 amps
Temperature Range. Storage Operating	-30C. to +60C. 0C. to +40C.
Humidity.	0% to 90% Non-Condensing.
Overall Size.	300mm x 130mm x 90mm High.
User Inputs.	24VDC @ 10mA. 150usec. rise time 5usec. fall time, source or sink link selectable by user.
User Outputs.	Maximum output switching current is approximately 500mA. at 50 VDC. with one output turned on. With all outputs turned on is 100mA. per output at 25C. Recommended maximum is 50mA.

1.0.2 Description.

The PMAC Four Axes Box is a fully integrated, stand alone position control and PLC system. Using the Power of PMAC this product is uniquely suited for small simple applications and larger more complex applications alike.

With Amplifier output signals of +/-10Vdc and pulse and direction the Four Axes Box is totally flexible in the mix of drives used on a system.

I/O availability and control is always a priority in systems but the PMAC Four Axes Box takes the user to new levels of simplicity. With 8 inputs and 8 outputs expandable in blocks of 32 inputs and outputs there is never a shortage of hardware. Also, with 64 independent

PLC's the user can more easily than ever, create programmes with both synchronous and asynchronous I/O control. Whether creating operator control panels or controlling and monitoring I/O while axes are moving it's never been more precise than with the

integrated philosophy of PMAC which put both PLC and motion control in one, easy to use package.

Simple or sophisticated? You choose. The extensive command library of PMAC together with its open architecture means you will never find yourself stuck for a control solution.

The Four Axes Box comes complete with two communications ports, one RS232 and one USB port, which means communications to operator control panels and computers for data transfer or programming can be achieved with ease.

One Power supply is required to bring the Four Axes Box to life but internally, careful attention has been paid to the noise immunity of the system by utilising three separate power supplies. The first of these is the main PMAC internal supply, +5 volts then the +/- 12 volts supply PMAC DACs and opto driver electronics.

The input 24Vdc supply is also made available on adjacent connectors for convenient connection to power any external I/O

Connection to PMAC Four Axes Box is quick and simple using removable screw terminal connectors with earthing to the individual connectors.

Encoder feedback signals enter via 9 way D type connectors.

For CE compliance refer to section 2.0

1.0.3 Four Axes Box Ordering Information.

Description	Part Number	FAB	FAB-Lite
<p>Base version (no options) provides a 90mm x 95mm board with:</p> <ul style="list-style-type: none"> • 40 MHz DSP563xx CPU (80 MHz 560xx equivalent) • 128k x 24 internal zero-wait-state SRAM • 512k x 8 flash memory for user backup & firmware • Latest released firmware version • RS-232 serial interface • 4 channels axis interface circuitry, each including: <ul style="list-style-type: none"> • 12-bit +/-10V analog • Pulse-&-direction digital output • 3-channel differential/single-ended encoder input • 4 input flags, 2 output flags at TTL levels • 3 PWM top-and-bottom pairs (unbuffered) • 50-pin IDC header for amplifier/encoder interface • 34-pin IDC header for flag interface • PID/notch/feedforward servo algorithms • 1-year warranty from date of shipment • One manual per set of 1 to 4 PMACs in shipment (Cables, mounting plates, mating connectors not included) 	400-603670-10x	*	*
PC/104 bus stack interface	30A-603670-OPT	*	*
2-channel on-board 12-bit A/D converter	312-603670-OPT	*	
High-speed-communications/digital-I/O board (requires at least one of Opt 1A, 1B, 2, or 3)	300-603672-10X	*	*
12 Mbit/sec USB interface	3A1-603672-OPT	*	
On-board digital I/O: multiplexer port, "opto" port, "handwheel" port	303-603672-OPT	*	*
<p>PMAC Four Axes Box enclosure. Select any of the above items and add them to this item to receive a finished package.</p> <ul style="list-style-type: none"> • Single 24 VDC Supply required • Compact size 300mm x 130mm x 90m • CE compliant • AC opto-isolated user and axis flag inputs • Relay output on Amp enable signal • 8 opto isolated user I/P & 8 user O/P's available if ACC2P-Opt3 selected • LED status indicators for all Axis flags and user I/O • Expansion THW I/O port available for Acc34. • Handwheel I/P • RS232 as standard optional USB 		*	*

2.0 Recommended Installation Practices.

The Four Axis Box should be installed in accordance with the following standards:-

EN55011: 1991 Class A Emissions conducted
EN55022: 1987 Class A Emissions radiated
IEC801-4: 1988 2kv Fast Burst Transients
IEC801-2: 1991 ESD 8kv/4kv.

And if installed in accordance with these instructions it should comply with the Council Directive 89/336/EEC relating to electromagnetic compatibility.

- All cables connected to the Four Axis Box, with the exception of the power supply cable must be screened.
- All screened cables must be terminated at both ends of the cable.
- Mating D-Type connectors must have a metal shell and conform to the EMC Directive. The screen should not be terminated as one tail but should be splayed out uniformly and connected to the metal case.
- We recommend the use of foil type screened cable for the encoder connections. If a cable with a woven screen is used it may be necessary to fit a ferrite clamp on each of the cables at the entry point to the Four Axis Box.
- Where plug in Phoenix connectors are used each individual connector has it's own earth connector. The cable screen must be kept as short as possible and terminated using a crimp type ring termination. A recommendation is to pass the screen through the connector, pull it as close to the outer sheath as possible then crimp it. The exposed signal cables must also be kept as short as possible nominally 10-12mm. In this configuration the Four Axis Box should conform to class A emissions.
- Should the user require the system to conform to class B emissions it is likely that a ferrite clamp must be fitted around each screened cable that terminates onto a Phoenix connector. The clamp must be fitted as close to the earth point as possible.

3.0 Machine Amplifier and Encoder interface

3.0.1 Specification.

User Inputs.

Encoder inputs

5VDC link selectable on PMAC
as differential or single ended.

Limit Switch Inputs.

24VDC @ 10mA. 150usec. rise time,
5usec. fall time, source or sink link
selectable by user.

Home Flag Inputs.

24VDC @ 10mA. 150usec. rise time,
5usec. fall time, source or sink link
selectable by user.

Fault Inputs.

24VDC @ 10mA. 150usec. rise time,
5usec. fall time, source or sink link
selectable by user.

User Outputs.

Amplifier Enable
Output.

NC & NO Volt free contact with
common 100mA

Recommended maximum is 50mA.

3.0.2 General Description.

The Machine Amplifier and Encoder interface is designed to allow easy connection to the PMAC2/PC104 PMAC Housed within the unit.

It connects directly into PMAC Via the PC104 Header and supports all the control inputs and outputs.

The interface is designed for four axes. And supports both Stepper and analogue amplifier interfaces .

I/O Description.

Encoder inputs.

The encoder feedback signals enter the Four Axis Box via 9 pin D Type connectors. (socket mounted on the box).

Encoder signals can be single ended or differential, selectable on PMAC. Refer to PMAC2/PC104 manual for details

For CE compliance refer to section 2.0

Limit switch inputs

Opto coupled limit switch inputs use AC opto-isolators. These allow the opto-isolator inputs to be tied high or low referenced to the 24VDC I/O supply.

Green LED indicators are on when the limit switch is closed.

When an LED is off, that axis direction is disabled.

For CE compliance refer to section 2.0

Home flag inputs.

Opto coupled home flag inputs use AC opto-isolators. These allow the opto-isolator inputs to be tied high or low referenced to the 24VDC I/O supply.

Green LED indicators are on when the limit switch is closed.

When an LED is off, that axis direction is disabled.

For CE compliance refer to section 2.0

Fault inputs.

Opto coupled amplifier fault inputs use AC opto-isolators. These allow the opto-isolator inputs to be tied high or low referenced to the 24VDC I/O supply.

Green LED indicators are on when the fault input is on.

The sense of these inputs can be configured using Ix25 parameter in PMAC.

For CE compliance refer to section 2.0

Amplifier enable.

The amplifier enable output is a volt free single pole change over relay.

Analogue Command outputs #1 to #4.

These signals are derived directly from the PMAC and are maximum +/- 10VDC differential output.

To avoid damage to this output neither side should be connected to analogue 0 volts.

The DAC output limit is configured by Ix69 in PMAC.

A bias can be applied to this signal using Ix29 to overcome any offset in the amplifier.

For CE compliance refer to section 2.0

3.0.3 Power connections.

SYS_POWER	(5 pole Phoenix connector)
0VOLT	System Power supply 0V
0VOLT	System Power supply 0V
+24V	System Power supply 24V
+24V	System Power supply 24V
SCRN_PWR	Screen

IO_POWER	(5 pole Phoenix connector)
0VOLT	IO Power supply 0V
0VOLT	IO Power supply 0V
+24V	IO Power supply 24V
+24V	IO Power supply 24V
SCRN_PWR	Screen

The system power and IO power can be derived from separate 24V supplies or wired together from one supply.

4.0 Axis connections.

4.0.1 Axis flag input circuit.

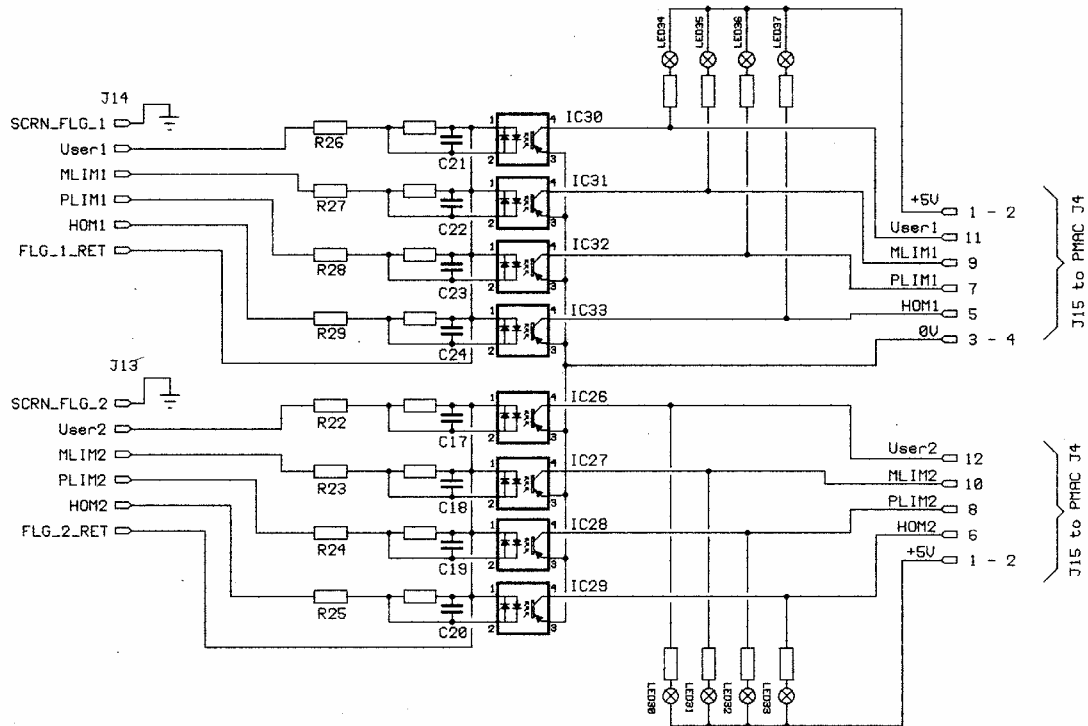

FLAGS1	(6 pole Phoenix connector)
SCRN_FLG_1	Screen
User1	USER1 Input General Capture Flag Sinking or sourcing
MLIM1	PLIM1 Input Positive Limit Flag Sinking or sourcing
PLIM1	MLIM1 Input Negative Limit Flag Sinking or sourcing
HOM1	HOME1 Input Home Flag Sinking or sourcing
FLG_1_RET	FLG_1_RET Input Return For All Flags +V (12 To 24v) or 0v

4.0.2 Amplifier and encoder connections

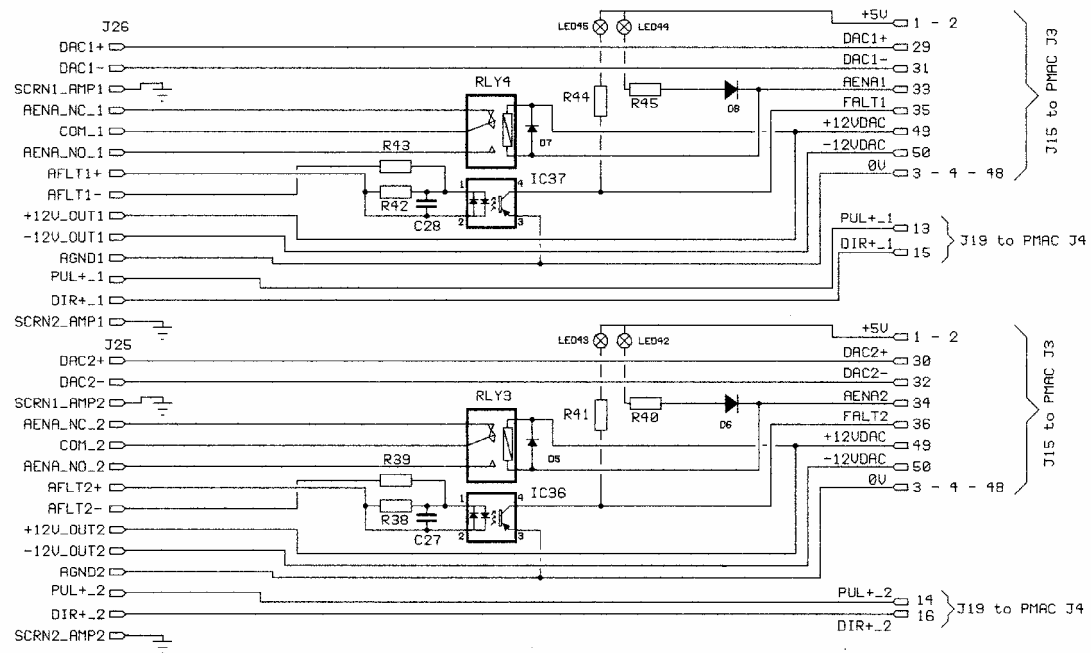

AMP1	(14 pole Phoenix connector)
DAC1+	DAC+
DAC1-	DAC-
SCRN1_AMP1	Screen
AENA_NC_1	Amplifier enable N/C
COM_1	Amplifier enable common
AENA_NO_1	Amplifier enable N/O
AFLT1+	Amplifier fault input
AFLT1-	Amplifier fault input
+12V_OUT1	+12V Output
-12V_OUT1	-12V Output
A_GND1	AGND
PUL+_1	PUL+
DIR+_1	DIR+
SCRN2_AMP1	Screen

ENC1	(DB9 Socket)
Pin	Function
1	CHA1+
2	CHB1+
3	CHC1+
4	N/C
5	+5V Output
6	CHA1-
7	CHB1-
8	CHC1-
9	0V

5.0 8 Input 8 Output Opto-isolated Interface.

5.0.1 Input circuit detail.

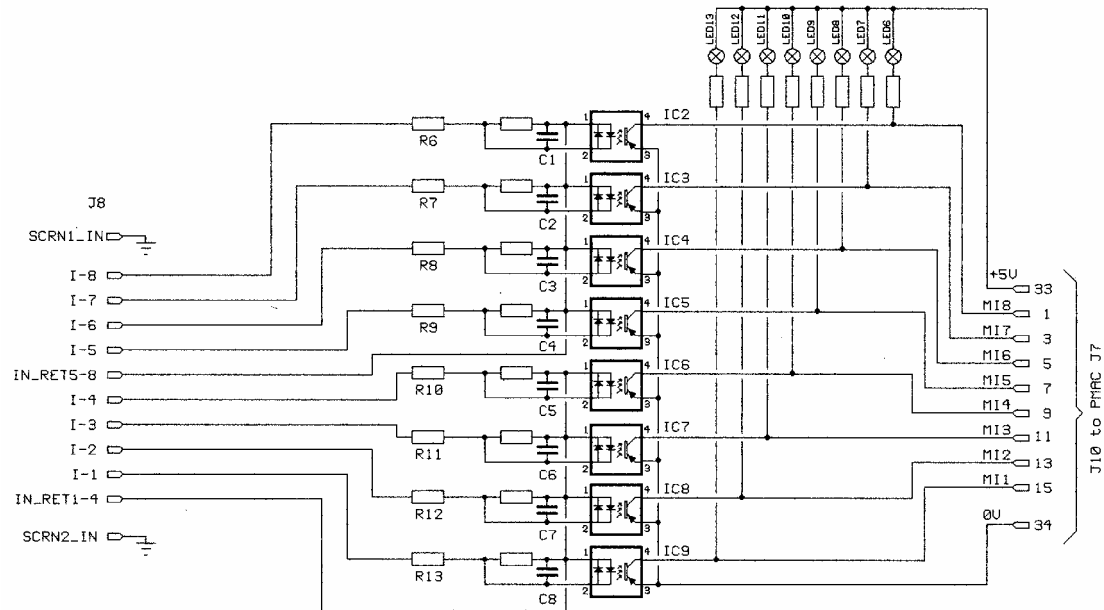

INPUTS	(12 pole Phoenix connector)
SCRNI_IN	Screen
I-8	IN-8 Input Digital input 12V to 24 V, sinking or sourcing
I-7	IN-7 Input Digital input 12V to 24 V, sinking or sourcing
I-6	IN-6 Input Digital input 12V to 24 V, sinking or sourcing
I-5	IN-5 Input Digital input 12V to 24 V, sinking or sourcing
I_-RTN5-8	RTN5-8 Input Return For Flags 0 to 3. 12 to 24 V or 0v
I-4	IN-4 Input Digital input 12V to 24 V, sinking or sourcing
I-3	IN-3 Input Digital input 12V to 24 V, sinking or sourcing
I-2	IN-2 Input Digital input 12V to 24 V, sinking or sourcing
I-1	IN-1 Input Digital input 12V to 24 V, sinking or sourcing
IN_RTN1-4	RTN1-4 Input Return For Flags 4 to 7. 12 to 24 V or 0v
SCRNI_IN	Screen

5.0.2 Output circuit detail.

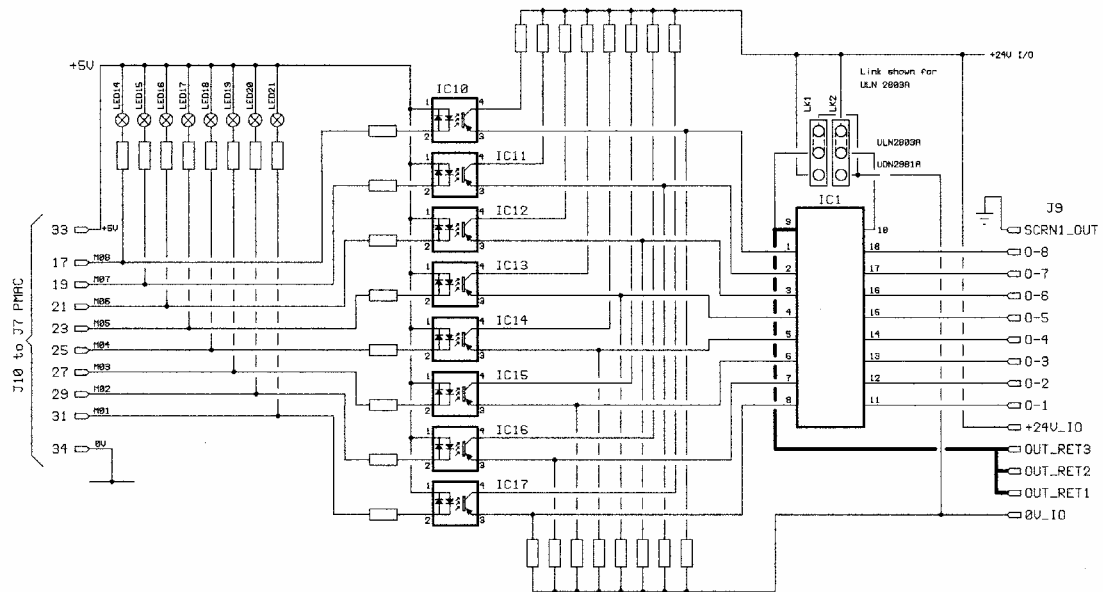

Default output device is UDN2981 to give sourcing outputs.

For inductive loads ensure back EMF suppression device is fitted

OUTPUTS	(14 pole Phoenix connector)
SCRNI_OUT	Screen
O-8	OUT-8 Output Digital output
O-7	OUT-7 Output Digital output
O-6	OUT-6 Output Digital output
O-5	OUT-5 Output Digital output
O-4	OUT-4 Output Digital output
O-3	OUT-3 Output Digital output
O-2	OUT-2 Output Digital output
O-1	OUT-1 Output Digital output
+24V I/O	OUT_+24V Output power supply
RET 3	Common for all outputs
RET 2	Common for all outputs
RET 1	Common for all outputs
0V I/O	OUT_0V Output power supply

6.0 Other ports.

6.0.1 Serial port

RS232	(DB9 Socket)
1	N.C. No connect
2	TXD/ Input Receive data host transmit data
3	RXD/ Output Send data host receive data
4	DSR Bi-directional Data Set Ready tied to DTR
5	GND Common
6	DTR Bi-directional Data Terminal Ready tied to DSR
7	CTS Input Clear to Send host ready bit
8	RTS Output Request to Send
9	N.C. No connect

The FAB can be connected to a PC using a standard 9 pin male-9 pin female 'modem' lead e.g. Belkin F2N209-06.

6.0.2 Thumbwheel multiplexer

THW_PORT	(DB25 Socket)
1	GND Common PMAC Common
2	DAT0 Input Data-0 Input Data Input from Thumbwheel Switches
3	DAT1 Input Data-1 Input Data Input from Thumbwheel Switches
4	DAT2 Input Data-2 Input Data Input from Thumbwheel Switches
5	DAT3 Input Data-3 Input Data Input from Thumbwheel Switches
6	DAT4 Input Data-4 Input Data Input from Thumbwheel Switches
7	DAT5 Input Data-5 Input Data Input from Thumbwheel Switches
8	DAT6 Input Data-6 Input Data Input from Thumbwheel Switches
9	DAT7 Input Data-7 Input Data Input from Thumbwheel Switches
10	N.C. No Connection
11	N.C. No Connection
12	N.C. No Connection
13	+5V Output +5VDC Supply Power Supply Out
14	GND Common PMAC Common
15	SEL0 Output Select-0 Output Scanner Output for reading TW Switches
16	SEL1 Output Select-1 Output Scanner Output for reading TW Switches
17	SEL2 Output Select-2 Output Scanner Output for reading TW Switches
18	SEL3 Output Select-3 Output Scanner Output for reading TW Switches
19	SEL4 Output Select-4 Output Scanner Output for reading TW Switches
20	SEL5 Output Select-5 Output Scanner Output for reading TW Switches
21	SEL6 Output Select-6 Output Scanner Output for reading TW Switches
22	SEL7 Output Select-7 Output Scanner Output for reading TW Switches
23	GND Common PMAC Common
24	GND Common PMAC Common
25	GND Common PMAC Common

The thumbwheel multiplexer port can either be used directly to provide additional 5V IO or used to connect to the PMAC ACC-34A multiplexed IO board. The ACC34-AA provides an additional 32 In and 32 Out 24V opto isolated IO.

6.0.3 Handwheel port

H WHL/STEP	(DB15 Socket)
1	Chassis ground
2	Chassis ground
3	HWA2+/PUL2+
4	HWA2-/PUL2-
5	HWB2+/DIR2+
6	HWB2-/DIR2-
7	+5V
8	0V
9	Chassis ground
10	HWB1-/DIR1-
11	HWB1+/DIR1+
12	HWA1-/PUL1-
13	HWA1+/PUL1+
14	+5V
15	0V

The default configuration is for handwheel encoder input. To change to stepper output jumpers E3 and E4 need to be changed. E3 controls channel 1 and E4 controls channel 2. Jumper 1-2 for handwheel input or 2-3 for stepper output.

;Handwheel stepper output

```
i500=1  
i502=$c094  
i503=$728  
i504=$728  
i525=$120770  
i530=700  
i532=15050  
i570=0
```

```
i600=1  
i602=$c09c  
i603=$729  
i604=$729  
i625=$120771  
i630=700  
i632=15050  
i670=0
```

```
i990=8 ;Internal encoder loopback  
i991=8 ;Internal encoder loopback
```

7.0 Four Axis Box Software Setup

The Four Axis Box is based on the PMAC2-PC/104 and uses PMAC2 firmware. As such setup similar to a PMAC2 board with a few exceptions. Several parameters for global and multi-channel hardware operation must be set for proper operation of the filtered PWM analogue channel outputs. The global hardware variables are in the **I900** to **I909** range (**I900-I905** for channels 1 through 4, **I906-I909** for channels 5 through 8). The only channel specific hardware variable is **I9n6**.

Parameters to Set Up Global Hardware Signals

I900

I900 determines the frequency of the **MaxPhase** clock signal from which the actual phase clock signal is derived. It also determines the PWM cycle frequency for Channels 1 to 4. This variable is set according to the equation:

$$I900 = \text{INT}[117,964.8/(4*\text{PWMFreq(KHz)}) - 1]$$

The PMAC2 PC/104 filtered PWM circuits were optimised for 30KHz. **I900** should be set to 1001 (calculated as 29.43KHz)

I901

I901 determines how the actual phase clock is generated from the **MaxPhase** clock, using the equation:

$$\text{PhaseFreq(kHz)} = \text{MaxPhaseFreq(kHz)}/(I901+1)$$

I901 is an integer value with a range of 0 to 15, permitting a division range of 1 to 16. Typically, the phase clock frequency is in the range of 8 kHz to 12 kHz. 9KHz is standard, set **I901** = 2 (calculated as 9.81 KHz).

I902

I902 determines how the servo clock is generated from the phase clock, using the equation:

$$\text{ServoFreq(KHz)} = \text{PhaseFreq(KHz)}/(I902+1)$$

I902 is an integer value with a range of 0 to 15, permitting a division range of 1 to 16. On the servo update, which occurs once per servo clock cycle, PMAC2 updates commanded position (interpolates) and closes the position/velocity servo loop for all active motors, whether or not commutation and/or a digital current loop is closed by PMAC2. Typical servo clock frequencies are 1 to 4 kHz. The PMAC standard is 2.26 KHz, set **I902** = 3 (calculated as 2.45 KHz).

I10 tells the PMAC2 interpolation routines how much time there is between servo clock cycles. It must be changed any time **I900**, **I901**, or **I902** is changed. **I10** can be set according to the formula:

$$I10 = (2*I900+3)(I901+1)(I902+1)*640/9$$

I10 should be set to 1710933.

I903

I903 determines the frequency of four hardware clock signals used for machine interface channels 1-4. This can be left at the default value of 2258. The four hardware clock signals are SCLK (encoder sample clock), PFM_CLK (pulse frequency modulator clock), DAC_CLK (digital-to-analogue converter clock), and ADC_CLK (analogue-to-digital converter clock).

Parameters to Set Up Per-Channel Hardware Signals

I9n6

I9n6 must be set to 0 to specify outputs in PWM format for the PWM active filter.

I-variables to get started

```
I10=1710933
I900=1001
I901=2
I902=3
I916=0
I926=0
I936=0
I946=0
```

For +/-10V output:

```
i169=512    ;#1 DAC output limit
i269=512    ;#2 DAC output limit
i369=512    ;#3 DAC output limit
i469=512    ;#4 DAC output limit
```

For Stepper output

Motor 1

```
I102=$c004
I130=700
I131=0
I132=32654
I910=8
```

IO Setup

Before the IO can be used M variable assignments must be made to address the hardware. The buffer direction registers must be configured to tell the buffers on the PMAC2-PC104 board to become outputs and not inputs. Because the Four Axis Box uses additional hardware to opto isolate the IO the setup is fixed at 8 inputs and 8 outputs.

The following example shows suggested M variable assignments and a simple PLC to configure the IO on power up.

```
M1->Y:$C080,0    ;Output 1
M2->Y:$C080,1    ;Output 2
M3->Y:$C080,2    ;Output 3
```

```

M4->Y:$C080,3      ;Output 4
M5->Y:$C080,4      ;Output 5
M6->Y:$C080,5      ;Output 6
M7->Y:$C080,6      ;Output 7
M8->Y:$C080,7      ;Output 8
M9->Y:$C080,0,8    ;All outputs

M11->Y:$C080,8     ;Input 1
M12->Y:$C080,9     ;Input 2
M13->Y:$C080,10    ;Input 3
M14->Y:$C080,11    ;Input 4
M15->Y:$C080,12    ;Input 5
M16->Y:$C080,13    ;Input 6
M17->Y:$C080,14    ;Input 7
M18->Y:$C080,15    ;Input 8
M19->Y:$C080,8,8   ;All inputs

M32->X:$C080,0,8   ;Direction control register
M33->Y:$E800,0     ;Buffer direction control register
M34->X:$C084,0,24  ;IO inversion control

I903 = 1746 ; Set ADC clock frequency at 4.9152 MHz
M105->X:$0710,12,12,S ; Analogue input 1
M205->X:$0711,12,12,S ; Analogue input 2

open plcl
clear
cmd"WX:$C014, $1FFFFFF" ; Clock strobe set for bipolar analogue inputs
M32=255      ;Direction control bits
M33=255      ;Buffer direction control
M34=65535    ;Invert FAB Inputs and Outputs
M9=0         ;Turn off all outputs
displcl
close

i5=2         ;Allow PLCs 1-31 to run

```

Accessory 34aa expansion IO setup

Accessory 34aa provides 32in/32out 24V opto isolated expansion IO. It is connected to the FAB via the 25 way THW multiplex port.

```

m1001->TWS:1      ; Input from acc34a
m1002->TWS:6      ; Output to acc34a
m1003->D:$770     ; Outputs mapped from single bits
m1004->D:$771     ; Output image word

m1005->D:$772     ;Inputs mapped to single bits
m1006->D:$773     ;Input image

m900->Y:$770,0    ; Output 0
m901->Y:$770,1
m902->Y:$770,2
m903->Y:$770,3
m904->Y:$770,4
m905->Y:$770,5
m906->Y:$770,6
m907->Y:$770,7    ; Output 7

m908->Y:$770,8    ; Output 8
m909->Y:$770,9
m910->Y:$770,10
m911->Y:$770,11
m912->Y:$770,12
m913->Y:$770,13
m914->Y:$770,14
m915->Y:$770,15   ; Output 15

```

```

m916->Y:$770,16 ; Output 16
m917->Y:$770,17
m918->Y:$770,18
m919->Y:$770,19
m920->Y:$770,20
m921->Y:$770,21
m922->Y:$770,22
m923->Y:$770,23 ; Output 23

m924->X:$770,0 ; Output 24
m925->X:$770,1
m926->X:$770,2
m927->X:$770,3
m928->X:$770,4
m929->X:$770,5
m930->X:$770,6
m931->X:$770,7 ; Output 31

m932->Y:$772,0 ; Input 0
m933->Y:$772,1
m934->Y:$772,2
m935->Y:$772,3
m936->Y:$772,4
m937->Y:$772,5
m938->Y:$772,6
m939->Y:$772,7 ; Input 7

m940->Y:$772,8 ; Input 8
m941->Y:$772,9
m942->Y:$772,10
m943->Y:$772,11
m944->Y:$772,12
m945->Y:$772,13
m946->Y:$772,14
m947->Y:$772,15 ; Input 15

m948->Y:$772,16 ; Input 16
m949->Y:$772,17
m950->Y:$772,18
m951->Y:$772,19
m952->Y:$772,20
m953->Y:$772,21
m954->Y:$772,22
m955->Y:$772,23 ; Input 23

m956->X:$772,0 ; Input 24
m957->X:$772,1
m958->X:$772,2
m959->X:$772,3
m960->X:$772,4
m961->X:$772,5
m962->X:$772,6
m963->X:$772,7 ; Input 31

open plc2
clear
;Process inputs
m1006=m1001
If (m1005 != m1006)
    m1005=m1006
EndIf

;Process outputs
If (m1003 != m1004)
    m1004=m1003 ; Update image
    m1002=m1004 ; Send image to Acc34a
EndIf
close

```

Dimensions

